

HHG Drums 1
Gamma Prototype Final Report

December 9, 2020



Brenna Stone
Sheila Moroney
Amanda Johnson
Justin Schmoyer
Jeffrey Will
Zaid Mohammad

Executive Summary

The goal of this project is to redesign a snare drum's lug, strainer, and butt plate to create a more unique and aesthetically pleasing look, while also maintaining the current level of functionality. Currently, the parts are functional and attractive, but lack a certain level of uniqueness that HHG Drums is looking for. The current foreign manufacturer is no longer to the standards set by HHG Drums, so with the new design comes the challenge of finding a manufacturer that can bring these redesigns to life. During the ideation process, the HHG Drums 1 team has taken into account different customer needs such as functionality, cost, durability, and ease of manufacturing, as well as the competition's current designs. Currently, the team is working towards a finalized design for the three parts. This report details the work of the Penn State HHG Drums 1 team through the concept selection stage of the design process.

Table of Contents

1.0	Introduction	
1.1	Initial Problem Statement.....	5
1.2	Objectives.....	5
2.0	Customer Needs Assessment	
2.1	Gathering Customer Input.....	6
2.2	Weighting of Customer Needs.....	7
3.0	External Search	
3.1	Patents.....	9
3.2	Existing Products.....	10
4.0	Engineering Specifications	
4.1	Establishing Target Specifications and Relating them to Customer Needs.....	14
5.0	Lug Concept Generation and Selection	
5.1	Problem Clarification.....	15
5.2	Concept Generation.....	15
5.3	Concept Selection.....	19
6.0	Alpha Prototype Details	
6.1	Alpha Prototype.....	22
6.2	Plans for Redesign and Beta Prototype.....	24
7.0	Strainer and Butt Plate Concept Generation and Selection	
7.1	Problem Clarification.....	25
7.2	Lug Redesign Concept Generation.....	25
7.3	Lug Redesign Concept Selection.....	26
7.4	Strainer Concept Generation.....	27
7.5	Strainer Concept Selection.....	30
7.6	Butt Plate Concept Generation.....	32
7.7	Butt Plate Concept Selection.....	35

8.0	Beta Prototype Details	
8.1	Building upon Alpha Prototype.....	37
8.2	Subsystems and Critical Functions.....	37
8.3	Evaluation of Prototype and Key Takeaways.....	38
8.4	Plans for Redesign and Gamma Prototype.....	39
9.0	Final Prototype Details	
9.1	Building upon Beta Prototype.....	41
9.2	Subsystems and Critical Functions.....	46
9.3	Prototype Evaluation.....	46
9.4	Lessons Learned.....	48
10.0	Next Steps	
10.1	Next Steps for Subsequent Capstone Team.....	49
10.2	Next Steps for HHG Drums.....	49
	References.....	50
	Appendix.....	51

1.0 Introduction

1.1 Initial Problem Statement

The HHG Drums 1 team is tasked with redesigning three snare drum components to create a more unique and aesthetically pleasing design. The components under review are the strainer, lug, and butt plate and while their current design is functional and attractive, they lack a certain flare that would set them apart from HHG Drum's competition. They currently come from a foreign manufacturer and do not represent the HHG Drums brand to the sponsor's liking. These three parts are attached to the outside of the drum and give the drum its functionality as they keep the drum tensioned and have the snare wires on the bottom of the drum. The team will be in charge of all parts of the engineering design process including identifying competitor designs, incorporating current designs and creating goals for new designs. Initial designs are to be shared with HHG Drums Owner and project sponsor, Mr. Sam Thureau, for his feedback and guidance on what direction to take concept selection in.

The project sponsor is seeking an innovative and extraordinary redesign of three snare drum components, the strainer, lug, and butt plate, that not only stand out among the competition but represent the HHG Drums brand as it continues to build its reputation in the drumming industry.

1.2 Objectives

The HHG Drums 1 team will work in partial collaboration with HHG Drums 2 on competitor research, but will part ways during the concept generation and selection phases to ensure original and organic designs are produced by the team. The semester-long effort concludes in December with a non-functional 3D printed prototype of the final model designs of the strainer, lug, and butt plate.

The team is currently constrained to an online working environment resulting from the Coronavirus pandemic. Milestones that the team is currently working towards that will help accomplish the problem outlined in Section 1.1 are the concept selection matrix and finalizing competitor research.

2.0 Customer Needs Assessment

2.1 Gathering Customer Input

Our team, assigned by Penn State to HHG Drums, is tasked with designing a new solution for drum components that are both functional and aesthetically pleasing. To accomplish this goal, three components of a drum which must be designed. These components consist of the lugs, strainer and butt plate. Using information provided by the sponsor, a preliminary list of customer requirements was generated. The following are the customer needs determined by the team:

- The product needs to be easy to use.
- The product needs to be aesthetically pleasing.
- The product needs to be able to apply tension on the head.
- The product needs to be durable.
- The product needs to be adjustable.
- The product needs to be manufacturable.
- The product needs to be able to toggle the snare wire.

The team then took this basic list and further developed it into a detailed list with specific requirements. Sharing these requirements with the sponsor, revisions were completed to create an agreement of a finalized list. Two different sections were created which include general and part specific requirements. From here, the team developed a needs/metric matrix which can be found below in Table 2.1. Since all the components shared general requirements, a custom color scheme was created to distinguish the part specific requirements. Customer needs in a grey box pertain to all components while blue boxes relate to the lugs, green boxes for the strainer and yellow boxes for the butt plate.

While most metrics only applied to a single customer need, a few did not. This happens when a metric is able to be a measure of multiple customer needs. The first example of this is how the product needing to be castable and affordable relates to the number of complex internal geometries. By reducing the complex internal geometries, the complexity and cost to cast goes down because the molding process is easier. Another example of this would be how the product needing to be both durable and securely attached to the drum are related to the metric of number of attachment points. Increasing the number of points the hardware is attached by would increase both durability and security. The last example of off-diagonality would be the product needs to apply tension to the head and snare wire relating to the range of tension required. Since both parts need tension applied, the range of tensions would be the same.

Table 2.1. Customer Needs and Metrics

		Metrics											
		Degree of aesthetic pleasure	Number of complex internal geometry	Lifespan of product	Total cost of product	Assembly time	Number of attachment points	Range of drum sizes	Size of footprint	Angle of attachment	Range of tension	Speed of product	Amount of clamping force
Customer Needs	The product needs to be creative and innovative	X											
	The product needs to be castable		X										
	The product needs to be durable			X			X						
	The product needs to be affordable		X		X								
	The product needs to be easy to assemble					X							
	The product needs to securely attach to the drum						X						
	The product needs to be usable on different sized drums							X					
	The product needs to have a small footprint								X				
	The product needs to contain adjustability for different size drum hoops									X			
	The product needs to be able to apply tension to the drumhead										X		
	The product needs to be able to quickly toggle the snare on and off											X	
	The product needs to have adjustability in the snare wire tension										X		
	The product needs to securely reatin the drum wires												X
		Minimum	7	0	5 years	\$15	1 minute	1	10 in	0.5" x 0.5"	-10 degrees	0 lbs-in	0.5 sec
	Maximum	10	2	50 years	\$80	10 minutes	3	24 in	1.5" x 1.5"	10 degrees	100 lbs-in	2 sec	150 lbs-in
		Target Values											

Note: Grey boxes are general requirements, blue boxes are lug specific requirements, green boxes are strainer specific requirements and yellow boxes are butt plate specific requirements.

2.2 Weighing of the Customer Needs

Using the needs/metrics matrix and input from the sponsor, a level of importance was given for each customer requirement. To judge the level of importance for each customer requirement, the team reviewed each requirement individually and ranked the requirements between 1 and 5. A rounded average of every member score per requirement was taken and assigned to the requirement. A score of 5 is related to having the highest importance while a 1 is the lowest importance. The list of customer requirements, their related metrics and their related level of importance is provided in Table 2.2.

A variety of different testing methods will be used when comparing the metrics to the customer needs. These tests can include but are not limited to: Instagram surveys, costing analysis, assembly time testing and lifetime testing.

Table 2.2. Customer Needs, Metrics and Importance

Needs	Metrics	Importance
The product needs to be creative and innovative	7/10 - 10/10 rating	5
The product needs to be castable	0 - 2 Complex internal geometries	2
The product needs to be durable	Last 5 - 50 years	3
The product needs to be affordable	\$15 - \$80	4
The product needs to be easy to assemble	1 - 10 minutes	2
The product needs to securely attach to the drum	1 - 3 contact points	3
The product needs to be usable on different sized drums	10 - 24 inch drum	5
The product needs to have a small footprint	0.5"-1.5" x 0.5"-1.5"	4
The product needs to contain adjustability for different size drum hoops.	-10 to 10 degree	3
The product needs to be able to apply tension to the drumhead.	0 - 100 lbs-in	4
The product needs to be able to quickly toggle the snare on and off.	0.5 - 2 sec	4
The product needs to have adjustability in the snare wire tension	0 - 100 lbs-in	3
The product needs to securely retain the drum wires	0 - 150 lbs-in	3

Note: Grey boxes are general requirements, blue boxes are lug specific requirements, green boxes are strainer specific requirements and yellow boxes are butt plate specific requirements.

3.0 External Search

Research was performed with the intent to determine design and aesthetic options. Patents and existing products were examined to determine characteristics and features that the team desired for the alpha prototype design. Current snare drums and patents vary vastly, so these are only some of the options that the team analyzed.

3.1 Patents

US20150317962A1 - This patent pertains to the mechanism for a snare strainer. In this strainer, the throw rotates around the cylindrical body so that there isn't any dual lever actuator. This allows for the motion to be smooth and consistent. It also offers advanced adjustability. We had been asked not to use this type of strainer, regardless if there was a patent, due to its high cost and machining time. We were still asked by our sponsor to research if there was a patent for this type of mechanism.

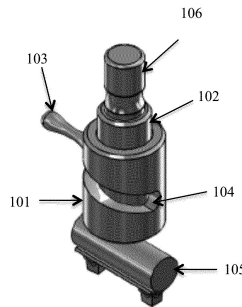

Figure 3.1. Helical Throw Style Strainer

US9934766B2 - The strainer in this patent would not be a strainer concept we would be interested in, but was one of the few other current patents on snare strainers. This patent is for a strainer for high tension drum heads, which does not apply for our purpose, and contains a connecting rod between the strainer and butt plate strainer for adjustability through the drum. This would not be the direction we would head with our design due to the extensive amount of metal hardware used, which opposes our goal of a simplistic and minimalistic design.

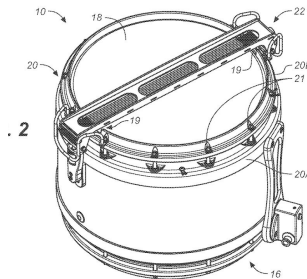

Figure 2. Through Shell Adjustable Strainer

3.2 Existing Products

Countless companies manufacture snare drums for the mass markets. Companies have certain criteria when designing a snare drum for a specific market. The easiest way to dissect competitor products and designs would be to look at their target audience. There are entire markets regarding the production of snare drums, and entire drum sets for that matter, around the intention of use for beginners and kids. It is important to note that the entirety of our target consumer would not be in this category. The most important determination regarding the target audience pertains to the quality and aesthetic goals for the project, and due to the vast differences between target audiences, we will focus just on products and components from a similar market.

Snare drums consist of multiple components that can be changed and varied for a final design. These components are the snare strainer, lug design, and butt plate, with exception to the shell and rims. The rims and wooden shell realistically do not differ greatly between designs, especially on mass produced designs. These three components will be the aspects of competitor designs that we will focus on when analyzing competitor products.

The Tama S.L.P, as shown in Figure 1, became the first design we wanted to look at because of the ratio of quality to production rate with consideration of the price point. This snare drum is an extremely classic design consisting of elegant and simple designs for the metal components and is centered around a 14x5.5 inch maple shell. This drum was an excellent design to look at due to the target consumer for our design. Tama is a drum manufacturer that produces in large quantities but still keeps their quality high on specific drum lines. This drum is very minimalistic and, after speaking to our sponsor, appeals to the preferred aesthetics for experienced percussionists. The components of this drum can be analyzed further to incorporate aspects of each into our final design.



Figure 3. Tama SLP Snare Drum

Dual mounted lug designs are critical for every percussionist looking for a premium snare drum. When installing and tuning new drum heads (batter or side), it is critical for the heads to be tightened evenly and in a way with the least amount of tension or uneven forces on the lugs. Lateral tension in any form can pull on the head unevenly and cause premature head failure. This can also warp the lugs in extended use due to the static loads. When lugs are mounted with one

screw, the lugs will pivot in line with the lug screw mounting hole in the drum rim. When this happens, the rim and head could be mounted in a way that is not lined up with the lugs exactly. This would create a lot of uneven tension on the head due to the tendency of the rim to twist on the head.

As well as having a head being mounted correctly to protect the drum head, it also plays a significant factor in drum tuning retainment. If a drum is manufactured without dual mounting positions on the lugs, the uneven mounting and imperfect positioning can create an imbalance of force again, which could cause vibrations to affect head tension more than usual over time. This is something that can cause problems for the owner in terms of tuning and drum sound and performance.

In terms of this design, the lugs are mounted in two spots, with the lug screws mounting into both sides of the lugs. This design has been something we have thought about for a long time as a team. The idea that both lug screws could be mounted into the same lug, would allow less pieces to be manufactured per drum, which would save cost from a manufacturing perspective. The drawback of this design is a lack of forgiveness with tolerances for the physical manufacturing of the lug and shell, as well as the loss of versatility with drum sizes. This design would not necessarily work for a piccolo snare or a deep shell snare. After analyzing our options, we think that having the lugs separate (top and bottom) could yield more benefits than the contrary.

This design has a premium feature in the butt plate design. The butt plate itself is actually adjustable which is not common among many mass-produced designs. These designs cost more but allow for much more accurate and detailed tuning of the snares along the side head. Both the strainer and butt plate allow for the snares to be adjusted well, while keeping a design and aesthetic that is consistent with the rest of the drum: elegant and simplistic. Overall the strainer and mechanisms involved contribute to the general simplicity the drum design supports. This is a design we will look to emulate in the creation of our own design.

An important series for the group was the Mapex Black Panther Series. This is a new series from Mapex, a company that is similar to Tama in its size and outreach into the percussion community. Mapex drums typically have more hardware with more complexities and intricacies in their design. The team came together in our thoughts on the Mapex series and analyzed a few of their designs within. The Black Panther Series offers multiple design options depending on which drum is chosen. They offer multiple different sizes of snare drums as well, which allows us to analyze how they approached the problem of different shell depths with lug solutions.

The Heartbreaker snare drum is shown in Figure 2. In this series is a 14x6 inch mahogany shell and has a lug design that is extremely elegant and simple, which is slightly different from Mapex's typical design choices. This drum looks very similar to the Tama S.L.P. and has a similar design goal in mind. The aesthetics are very similar and the metal has a polished finish which is a traditional look for snare drums.



Figure 4. The Heartbreaker Snare Drum

This drum has very similar characteristics compared to the Tama mentioned earlier. One important detail to notice is the release date. The Black Panther series of Mapex snare drums is brand new in 2020. This is very interesting, because the series contains two very different designs in terms of aesthetics, and the group noticed this immediately.

The other design that Mapex offers in this new line of snare drums, is the Cherry Bomb. The Cherry Bomb seems to have an opposing design goal when comparing these designs. A Cherry wood makeup of the shell makes an impact initially, with a size of 13x5.5 inches. The next component of the drum that causes the viewer to step back are the lugs. The lugs are very sharp and angular, which is quite different from the Heartbreaker design, and reminded us personally of the black panther statue from the movie *Black Panther*. Regardless of any of the other features of the drum, the most impactful and striking aesthetic detail; is the powder coated finish to all the hardware on the drum. It is dark but very sleek and fits really well with the Cherry colored shell.



Figure 5. Cherry Bomb Snare Drum

Overall, the design of the Cherry Bomb is somewhat bulky and angular, which is not the direction we are looking to head in, but it offers us a contrasting design, by a major company, to consider. Some of the biggest takeaways from these designs were that the company decided on

different lugs, within a series, for shell compatibility. It intrigued the group that a large company could be successful with two very different designs in the same series and have each be aesthetically pleasing and functionally sound. They opened our eyes into how impactful every design decision can be, in terms of the entire snare drum's final visual aspirations.

4.0 Engineering Specifications

4.1 Establishing Target Specifications and Relating to Customer Needs

The team closely worked with the project company to understand their needs and developed a customer needs matrix. Keeping the customer needs as our priority, our team inferred from the requirements to develop target specifications. Our team has been given a free hand in designing the parts to look aesthetically pleasing, provided that it matches all the requirements. The components are to be designed to be able to be used in different sizes of drums ranging from 10 inches to 24 inches. The team chose these specifications because when researching HHG Drums, the height of different types of drums ranged from 10 inches to 24 inches. The footprint of the lug is to be under a span of 0.5*1.5 inches so that it can fit on the center ring easily. A lot of HHG Drums' products have a contour design, limiting how large a lug can be. The load-bearing capacity of the lug should be enough to provide tension from 0-100 lbs per inch. This target specification is needed so the customers can apply ample force to the drum without it breaking. The components are to be created with castable parts, for consistency and reduced production cost when compared to the CNC machine. The lug attachment should have between 1-3 holes for easy mounting of the lugs, requiring less machining. The design should be compatible with different sizes of drum hoops ranging from -10 to 10 degrees. This value was obtained from online research on most common drum hoop angles. Each and every one of these target specifications are vital for the customer needs to be satisfied.

5.0 Concept Generation and Selection

For the given project, the team wanted to create a unique, yet simple design for a snare drum's lug, strainer, and butt plate that HHG Drums can proudly display in all of the products. Sleek, functional parts were the end goal of this project. The initial designs formed in the concept generation process will be shown in the section below. Each of these designs had their own pros and cons, proving that teamwork and sharing individual ideas would help to create the best design possible. Below shows the team's thought process on how an idea turned more into a reality.

5.1 Problem Clarification

The team was tasked to create three different parts for the company HHG Drums. When starting the concept generation process, different variables were kept in mind. These included things such as cost, functionality, uniqueness, aesthetics and many more things. The team took these end goal ideas into consideration when starting to design different concepts. The team quickly discovered that the lug is the most important piece that they had to design, and the strainer and butt plate would inevitably follow to mock a similar design of the finalized lug idea. Below shows the teams concept generation processes and ideas for drum lug designs.

5.2 Concept Generation

After thorough research on customer needs and existing market products, we started the phase of concept generation. Throughout the process of concept generation, our primary focus was to create the components which appear to be exquisite and aesthetically pleasing. To create the three target components strainer, lug, and butt plate in a synchronous theme the group decided to design the lug first and then taking the inspiration from lug design to create the other two components. The base of our concept generation was prepared by an in-depth analysis of our customer needs and the problems they face with existing available products in the market.

We primarily divided our concept generation process into three parts:

- Brainstorming of ideas: Our group started with taking inspiration from the designs provided by our team sponsor. This gave a very good insight into the component designs and a vast variety of options to explore from. Thereafter, the team collectively created a file where all the research designs were collected, with hundreds of different designs to get inspired from. Each of the team members got two different designs of the three components, which they thought were the best fit for the application. Across many meetings and discussions, In the brainstorming stage, we collected a vast collection of ideas in the form of rough hand sketch drawing to 3D sketch SolidWorks files.
- Idea screening: this stage comprises the filtering of ideas collected throughout the brainstorming stage. Through a discussion we decided to divide the concepts into three

groups promising concepts, further discussion required concepts, and rejected concepts. The division into three different groups gave a narrower selection of designs that were approved by the majority of the group.

- Concept development: This is the process that is still under progress. The primary purpose of this process is to finalize and generate a concept from the ideas selected through the previous two sections. In this stage to get the final concept, we create a variety of concepts generated through fusion ideas to collectively help in selecting the most relevant concept for the purpose.

Concept A

Shown in Figure 4, Concept A is the result of introducing uniqueness into the idea. The main idea of this concept was to have two lugs connected to each other, while being able to still operate separately on larger drums. The backbone behind this concept was so the lugs could have two completely different looks when they are together versus when they are apart. It's versatility for different types of drums could turn out to be extremely useful when manufacturing the different drum parts. Although the concept of having lugs connect was genius, the design itself is rather sharp and rigid; it was not necessarily what the mentor was looking for in terms of aesthetics.

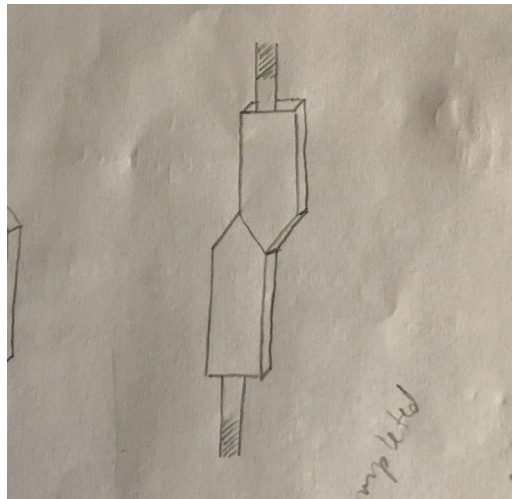

Figure 5.1. Concept A Drawing

Concept B

This design was created to have the operational function of using a barrel nut within the design. A lug with a barrel nut as its support is a very beneficial design for the reasoning that it is cross-functional to all different types of drums. The HHG Drums owner also has a lot of experience using this kind of hardware. The idea shows the barrels next to each other, but not connected. This design would in fact work on a contour drum shell, where the only part a lug could be mounted to is the middle part of the drum with about 1 ½ inches of space to work with. Functionally, concept B would work great, but it does not follow the aesthetics that the business owner had envisioned. It is very bulky and does not have soft edges.

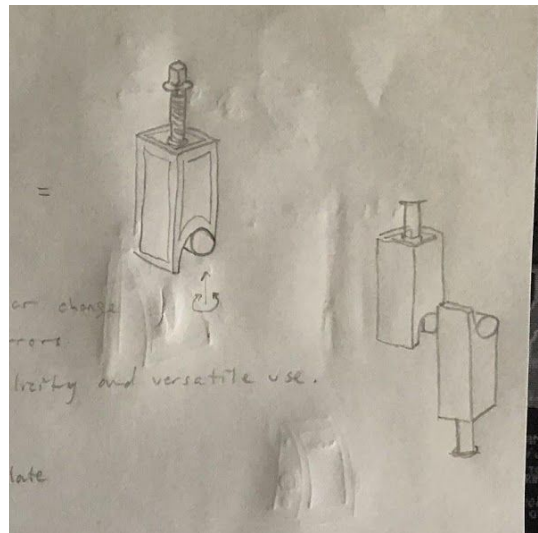

Figure 5.2 Concept B Drawing

Concept C

This design had the aesthetics down to a tee. Concept C, as shown in Figure 6, incorporates the curved edges and lines, just as the mentor likes. It is inspired by grand windows in his cabin house. The extruded pieces on the side view replicate those exact windows. With this design, there would only be one lug used instead of two. This would be fine if the lug was being used for snare drums and snare drums only, but if the owner ever decides that he wants to use the lugs on other types of drums, he would have to redesign the concept. For this reasoning, the team thought it would be safe to use a concept of two lugs in the final design.

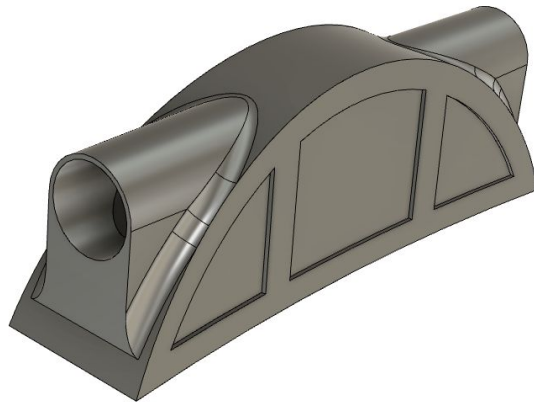

Figure 5.3 Concept C Drawing

Concept D

In Figure 7, Concept D displays a wave like feature that is attached to the drum wall. The two lug design accommodates the barrel nut feature that allows flexibility in different types of drums that this lug model could be used for. The curved features is aesthetically pleasing and possesses soft, rounded edges that will inevitably match the owner's drum style better. Most importantly, this design is easy to cast and manufacturer due to its simplicity. That aspect is extremely important to the owner because he would like to start producing drum hardware in the United States.

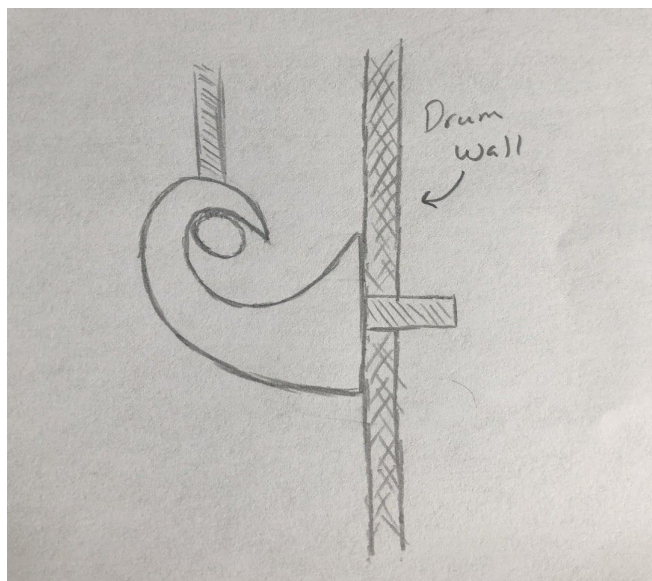

Figure 5.4 Concept D Drawing

5.3 Concept Selection

After narrowing down the teams' ideas to the four concepts shown above, the concept selection process begins for deciding which idea will best suit HHG Drum's wants and needs. To determine this, the team decided to create a concept selection matrix with different criteria to judge each design off of. To pick the variables, the team looked at the customer needs matrix to determine which variables were the most important. It made the most logical sense to use the general requirements that are needed for all three drum parts. Those needs were considered to be the most important for the team's final product. The variables chosen for the matrix included cost, aesthetic, durability, ease of manufacture, ease of assembly, and functionality. Each variable was given weight collectively by the group. These numbers were based on level of importance. Each group member wrote down their own opinion on what the weights should be, and the group as a whole averaged out the numbers to get the weight percentages. Table 5.1 represents all of the concept ideas, weights for each type of criteria and the ranking for each category. The ranking was on a scale of 1-5, with 1 being the lowest score and 5 being the highest score a concept could achieve. The purpose of a concept selection matrix is to determine which concept will result in the best product for HHG Drums.

Concept A

Pros: The sponsor really enjoyed the idea behind this design. Having lugs that connect together is something that he has never seen before and would love if HHG Drums could be the first company to do this tactic. The aesthetics for this concept is rated higher in the matrix due to its originality and uniqueness.

Cons: A huge concern for this concept is that it would be more on the difficult side to manufacture. Because the parts have to connect together, variability and tolerances become a concern when using additive manufacturing. Two lugs will also make the assembly process a little harder due to the fact that there will have to be more holes drilled into the drums and the risk of the parts not fitting together comes into play.

Takeaways: Concept A presents a whole new look to the drum industry. The uniqueness of lugs connecting together would inevitably be a changing point. Although the design is different, it does contain hard, sharp edges that the sponsor does not necessarily favor. It would also be harder to manufacture and assemble because the parts have to connect.

Concept B

Pros: Because this concept is thick and bulky, its durability is rated very high. If the drum were dropped or mishandled, the lug would most likely not break due to its sturdiness. This part is also extremely easy to manufacture. The main operation would be a quick cut extrusion from a block and the piece would be mostly finished. The barrel nut design allows the piece to have some variation, while still being able to attach and assemble the barrel nut to the lug.

Cons: The aesthetics on this design is what largely decreased this concept's score. The design is very bulky and would stick out/draw too much attention on the drums. The sponsor is looking more for subtle curves and edges that flow with the drum design itself.

Takeaways: Overall, Concept B was not what the sponsor was looking for in terms of being visually appealing. He did not believe that the design would match his current drum ambience. The design would be easy to manufacture and assemble due to only one hole need to be attached to each lug.

Concept C

Pros: The idea and design behind Concept C was very well put together. The lug had rounded features and would fit well with the sponsor's other drum components. The idea incorporated a meaningful design, representing a lot of the sponsor's inspiration. The drum would also be relatively easy to manufacture and assemble because of the one point contact with the drum wall.

Cons: Because Concept C is only one lug, instead of two, the idea would only work on snare drums. It would not be cross-functional to other types of drums due to the fact that the lug can only hold one-sized wire. This decreases the functionality score significantly. The part would also cost more because it is much larger in size and would require a lot more material.

Takeaways: The aesthetics part of this concept is exceptional because it incorporates something meaningful to the sponsor, while also fitting in with the company's drum aura. Being an only one lug design is a major setback because it limits the parts functionality. The team believes that they should produce a part that could be used on all drum types.

Concept D

Pros: Concept D possessed the best design in terms of looks. This design was the one that the sponsor showed most interest in when he saw all of the designs. This concept would be relatively easy to assemble because it is a smaller part that only requires one point of assembly between the

lug and drum wall. The design also scored high in functionality because it is a barrel nut design that can be used on any type of drum.

Cons: There are no major cons to this concept. It will be about average cost because there will be a need to produce two lugs where one lug would normally go on the drum wall. It is also relatively durable to the point where the lug should not break if the drum is dropped. It is also easy to manufacture using a cast process.

Takeaways: Concept D is the best design according to the concept selection matrix, Table 5.1. It has the highest score out of all of the options. It is above average in aesthetics, ease of assembly and functionality. It also contains the least amount of cons. The aesthetics of this design is really what brought this idea to the top.

Table 5.1: Concept Selection Matrix

Selection Criteria	Weight	Reference Concept		Concept A		Concept B		Concept C		Concept D	
		Ranking	Weighted Score	Ranking	Weighted Score	Ranking	Weighted Score	Ranking	Weighted Score	Ranking	Weighted Score
Cost	5%	3	0.15	3	0.15	3	0.15	2	0.1	3	0.15
Aesthetic	50%	3	1.5	4	2	1	0.5	5	2.5	5	2.5
Durability	10%	3	0.3	3	0.3	4	0.4	3	0.3	3	0.3
Ease of Manufacture	15%	3	0.45	2	0.3	4	0.6	3	0.45	3	0.45
Ease of Assembly	10%	3	0.3	2	0.2	3	0.3	3	0.3	4	0.4
Functionality	10%	3	0.3	3	0.3	3	0.3	2	0.2	4	0.4
Overall Score			3		3.25		2.25		3.85		4.2

6.0 Alpha Prototype

In this section we will discuss our alpha prototype and our plans for creating a successful beta prototype.

6.1 Alpha Prototype

After we chose to move forward with concept D, we created a CAD model and a non-functional 3D printed part for our alpha prototype. We picked concept D because it had the most organic design and seemed to match the aesthetic of HHG Drums the best. Since aesthetic was the most heavily weighted criteria in our selection matrix, it was a clear winner. This design will use a barrel nut as the tensioning function. Most drums use a floating tension mechanism that includes a spring. These lugs can often deteriorate over time as the springs loosen. The barrel nut functionality will match HHG Drums' high quality products. A barrel nut allows the tensioning rod to rotate around the axis of the nut. This function makes it easier to fine tune the tension of the drum head. As seen in Figure 6.1, the rendered CAD model resembles the sketch from concept D but has sleek curves and an organic feel. For our final prototype, we plan to cast the lugs so the sleek design goes hand in hand with our intended manufacturing process.



Figure 6.1. Rendered CAD model of prototype lug

Once the CAD model was completed, we 3D printed a version to get a better idea of our prototype and how it would look in person with the barrel nut included. In Figure 6.2, it is more clear how the barrel nut fits in with the lug. The wave-like style of the lug complements the barrel nut perfectly. We hope to keep this in mind while redesign the piece for the beta prototype.



Figure 6.2. 3D Printed Alpha Prototype

And finally, to get a better idea of how the lugs will look once the project is finished, we rendered a model on one of HHG Drums' signature styles, the contour drum, shown in Figure 6.2. In this iteration of our alpha prototype we can see how the lugs compliment this specific style. By using a two-lug system, our design is more versatile. The lugs can be used on normal snare drums, contour snare drums and also bigger drums.



Figure 6.2. Lug Design Rendered with example of an HHG Drum

6.2 Plans for Redesign and Beta Prototype

In this section we will discuss our plans for redesigning our current lug and how we can improve it for the next prototype. Then we will discuss how we will design the butt plate and strainer. We will also discuss how we will validate our manufacturing process for the parts we create.

After reviewing our alpha prototype, we enjoyed most of the aesthetics when observing the lug on its own. However, after seeing the lug both in person as a 3D printed part and rendered on the drum, we determined that it was much bulkier than we intended. Our team will perform a redesign to make the lug less bulky, but still maintain the function of holding the barrel nut. We also enjoyed some aspects of the other concepts during our concept selection phase. One of them being the incorporation of the sponsor's cabin windows. If we can find a way to subtly include window shapes in our two-lug system, it would add a personal story to the lug design, completely unique from any competitors.

Once we have a more firm lug design, we will begin the concept generation and selection process for the strainer and butt plate. The strainer has specific functions and we will have to be careful to avoid any existing patents. It was important to us to design the lug first because that is the most important feature of a snare drum and the feature that is most important to our sponsor. We will use our lug design as a guide while generating concepts for our butt plate and strainer so that all the parts match as a set.

Our team is currently researching options for testing the manufacturability of the parts we create. We plan to use a casting simulation software such as Altair to make sure the part can be cast without solidifying first. This software will also allow us to add the necessary geometries for casting.

Our beta prototype will include a redesigned model of lug in addition to the new models of the strainer and butt plate. We will also include detailed analysis of the manufacturability of each part.

7.0 Strainer and Butt Plate Concept Generation and Selection

7.1 Problem Clarification

The team was tasked to create three different parts for the company HHG Drums. When starting the concept generation process, different variables were kept in mind. These included things such as cost, functionality, uniqueness, aesthetics and many more things. The team took these end goal ideas into consideration when starting to design different concepts. After the lug design was completed, the strainer and butt plates followed. The goal was to create an aesthetic over the three pieces that would create an overall appealing look when all paired together on the same snare drum. Below shows the team's concept generation processes and ideas for drum's lug redesign, strainer design and butt plate designs.

7.2 Lug Redesign Concept Generation

With the final lug concept selected at the end of the alpha prototype phase, the team decided to design one more lug to see if that one better fit the customer needs. The team allowed the sponsor to look at both designs and see which one he liked more. Both designs were well thought out and creative, so the winner was left up to the concept selection matrix for the two ideas.

Concept D

Introducing Concept D, this design is a sleek, yet simple lug part that is versatile on all different types of drums. The barrel nut feature allows the lug to fit on different sized drums due to the flexibility of snare wire not having to conform to a certain drum height. The not so complex lug is the perfect design that incorporates all different aesthetic aspects. The design on the side of the lug is intended to replicate the windows at the sponsor's cabin, being a meaningful symbol that HHG drums could represent. The small extrusion along the spine of the lug gives the design just enough flare to make it unique and unlike any other lug.

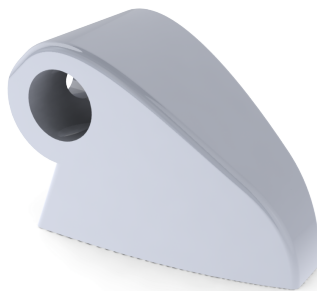

Figure 7.2.1: Concept D Lug Design

Concept E

Concept E displays a claw like feature that attaches to the drum wall. The two lug design accommodates the barrel nut feature that allows flexibility in different types of drums that this lug model could be used for. The curved features is aesthetically pleasing and possesses soft, rounded edges that will inevitably match the owner's drum style better. Most importantly, this design is easy to cast and manufacturer due to its simplicity. That aspect is extremely important to the owner because he would like to start producing drum hardware in the United States.

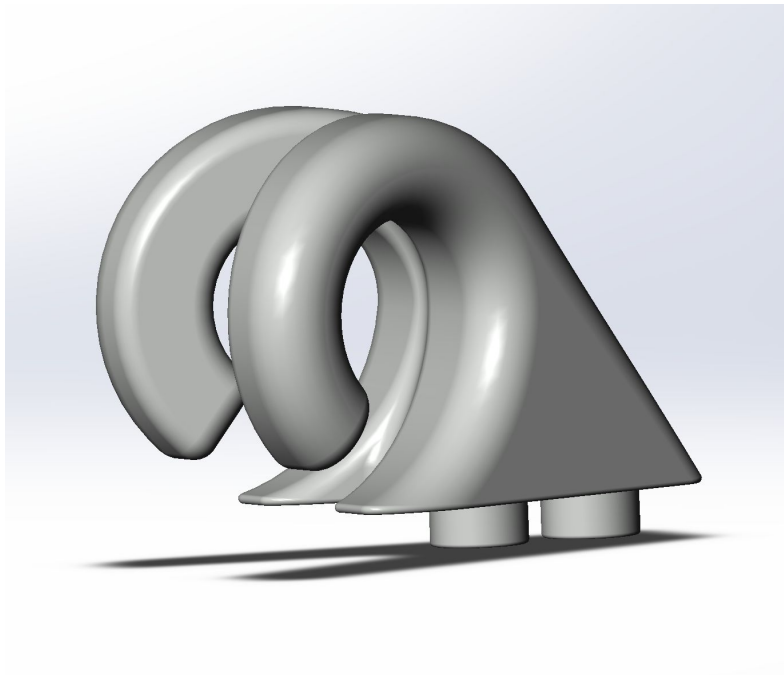

Figure 7.2.2: Concept E Lug Design

7.3 Lug Redesign Concept Selection

Concept D

Pros: Concept D's design is simple yet classy. The incorporation of the sponsor's cabin windows along with the smooth extrude rim gives the lug a nice, finished look. This piece is also extremely easy to cast considering the shape is similar to a quarter sphere where there is no implication of molten metal having a hard time to reach any places.

Cons: There are no major cons to this lug design. The piece is little bulky so it is definitely durable if the drum were to drop on the lug. The cost to produce is about average due to the fact that the lug is a heftier design compared to the other concepts, where it will require more material.

Takeaways: This concept is a safer option for HHG Drums to mass produce. The design is sleek and aesthetically pleasing. It is also easier to cast and more durable. This design wins in the concept selection matrix (shown in figure 7.3) due to the easier manufacturing process and being more widely liked by customers.

Concept E

Pros: Concept E design was the one that the sponsor showed most interest in when he saw all of the designs. This concept would be relatively easy to assemble because it is a smaller part that only requires one point of assembly between the lug and drum wall. The design also scored high in functionality because it is a barrel nut design that can be used on any type of drum.

Cons: This design is so unique that it may not be for all customers, meaning not everyone will like how out there the lug is because it has never been done before. It's considered to be an unsafe option not knowing whether the customers will jump on the idea or not. It will be about average cost because there will be a need to produce two lugs where one lug would normally go on the drum wall. It is also relatively durable to the point where the lug should not break if the drum is dropped.

Takeaways: Concept E has a very unique design but it could be risky presenting customers such an abstract idea. It is above average in aesthetics, ease of assembly and functionality. It also contains very little cons. The aesthetics of this design is really what brought this idea to the top two.

Table 7.3: Concept Selection Matrix for Lug Redesign

Selection Criteria	Weight	Reference Concept		Concept D		Concept E	
		Ranking	Weighted Score	Ranking	Weighted Score	Ranking	Weighted Score
Cost	5%	3	0.15	3	0.15	3	0.15
Aesthetic	50%	3	1.5	5	2.5	5	2.5
Durability	10%	3	0.3	5	0.5	3	0.3
Ease of Manufacture	15%	3	0.45	5	0.75	3	0.45
Ease of Assembly	10%	3	0.3	4	0.4	4	0.4
Functionality	10%	3	0.3	4	0.4	4	0.4
Overall Score			3		4.7		4.2

7.4 Strainer Concept Generation

After extensive research on customer needs and existing products, the team began the concept generation phase of the strainer. The design of the strainer came from the inspiration of the design on the lug and conversations with our project sponsor. The focus of the strainer design was to create something unique, while maintaining a modern and sleek design that would pair well with the lug.

Concept A

Introducing the first strainer design, Concept A, with a body shape that mimics the curvature of the snare drum itself. This sleek, yet simple, design incorporates many different aesthetic types. The geometric rectangular base emphasizes and compliments the curves of the body of a strainer. The basic screw seen at the top of the strainer and the lever shows on the side add to the simplistic design. More importantly, the basicness of the design makes it easy to manufacture, which has been a priority from the start of our design process.

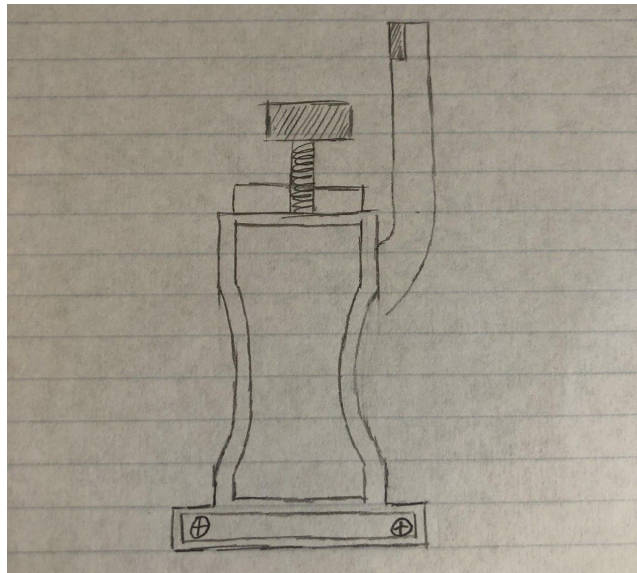

Figure 7.1 Concept A for Strainer Design

Concept B

Introducing Concept B with a more complex design than the previous Concept A. Starting at the top, when looking at the strainer from above, an HHG drums logo is shown as a way to brand the strainer. Next, the release lever represents an angled and curved shape, similar to the Nike swoosh logo. The body of the strainer grows narrow as it reaches the bottom of the strainer. Pairing this with the Nike swoosh inspired release lever, creates an overall sleek aesthetic that is unique from the current market. The design on the body of the strainer are extruded spines that replicate the lug design. By mimicking the lug designs key features on the strainer, the two components, when paired together create a holistic unique design for the snare drum that is complex and sleek.

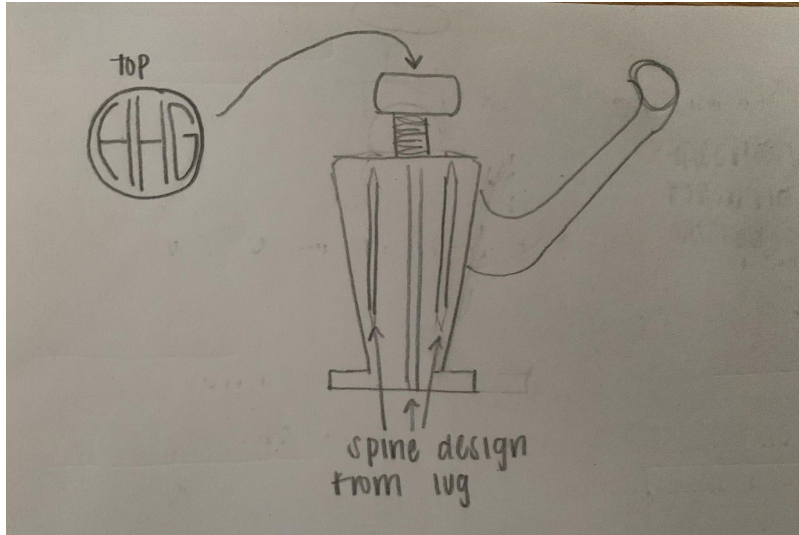

Figure 7.2: Concept B for Strainer Design

Concept C

Concept C is a simple design, with a screw that mimics the curvature of the snare drum. The twisted design of the release lever helps to create a unique strainer design, while keeping the body of the strainer more simple. The geometric shapes that make up this strainer design give a boxy and simplistic aesthetic. The thin, horizontally rectangular base paired with the wide, vertically rectangular body helps to elongate the strainer design. Additionally, these simple shapes make it easier to manufacture.



Figure 7.3: Concept C for Strainer Design

Concept D

Introducing the final strainer concept, Concept D, with a more complex and unique design than the others. Starting at the top, with a basic screw that is accompanied by a curved release lever that starts from the base of the strainer. The body of the strainer, as shown in the side view on the left, has a curved shape to it that sets it apart from anything else currently on the market. The cutouts on the body itself represent windows, an inspiration suggested by HHG drums that is very important to them. Pairing this design with the shape of the body gives it that over-the-top aesthetic that is sleek, while also giving it a shape that is not intrusive or too overpowering to the drum's current aesthetic.

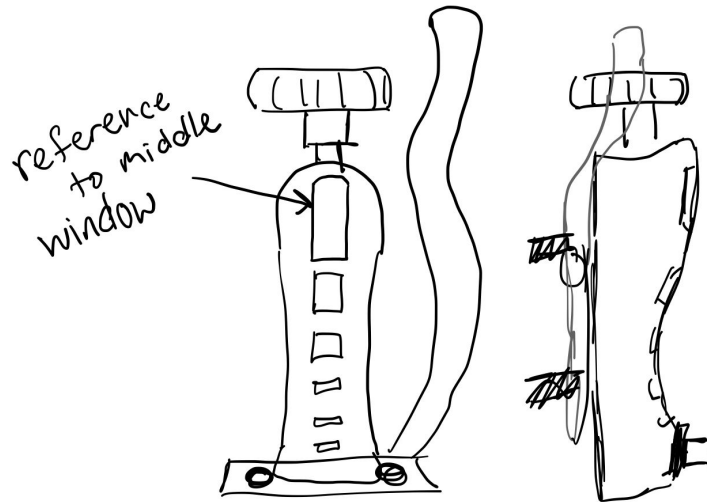

Figure 7.4: Concept D for Strainer Design

7.5 Strainer Concept Selection

After coming up with different strainer ideas, the concept selection process begins with stating the pros and cons of each idea. The whole purpose of this section is to narrow down the ideas into which one will best suit HHG Drums. To find the best possible option, the team decided to create a concept selection matrix, which emphasizes the goods and the bads of each design. The matrix uses a points system where each idea is ranked from 1 to 5 based on different categories and whichever design has the most amount of points at the end wins. To pick the variables, the team looked at the customer's needs matrix to discover which variables were most important. Going off the lug designs variables, the team decided to use the same variables for the strainer so there is consistency within the concept selection matrices. The variables decided before on the lug matrix consist of cost, aesthetic, durability, ease of manufacture, ease of assembly, and functionality. Each variable was given a weight based on the level of importance that variable serves for the final design product. The concept selection is shown in Table 7.5 where the variables, weights for each variable, and ranking score is displayed (1 being the lowest

and 5 being the highest). Next to each concept scoring, is the reference strainer used to create a base scale on how the other concepts should be ranked. The team decided to use a Ludwig P85 as the reference standard because this strainer is a very well made part, but it is not the best strainer on the market, nor the worst. The team wanted to use an average strainer so there could be room for improvement. The purpose of the concept selection matrix is to find the best possible product proposed.

Concept A

Pros: Concept A is a simple and classy design that is relatively easy to assemble and manufacture. Its high functionality levels also gave it an advantage over the other designs. The low cost to develop and manufacture was another positive attribute of the design. Overall, this design meets the unique aesthetic that the Sponsor was going for.

Cons: Concept A scored very well relative to the other strainer designs. There are no stand alone concerns regarding this design. The design is unique which can raise concerns that this design may not be for all customers.

Takeaways: Ultimately, Concept A scored the highest among all of the designs and was chosen to move forward with. The geometric shape and ease of manufacturing and assembly were key contributors as well as its aesthetic design. The sponsor reacted the most positively to this design.

Concept B

Pros: Concept B was unique in that it mimicked the design aesthetic of the lug and had a logo on the top of the knob as a way to show brand awareness. The overall design is sleek and uses a slimming strainer body to enhance the sleek appearance.

Cons: There are no outlying cons to concept B, but it did not meet the criteria as well as concept A did. Because this design is more complex than concept A, it will be more costly and not as easy to manufacture and assemble.

Takeaways: Overall, Concept B was a strong contender for the strainer design. Its sleek design that promotes brand awareness and replicated the lug's unique spine design was ultimately not what the Sponsor was looking for.

Concept C

Pros: Concept C was a very simple design with its most complex feature being the knob that had similar curvature to the snare drum itself. The simplicity of the design causes a low cost and a high ease of manufacturing.

Cons: Concept C’s simple design was not up the standards set by the Sponsor in terms of uniqueness. While it is still unlike the current market, it is lacking the “wow” factor that the Sponsor was hoping for.

Takeaways: Concept C posed as a base design because of its simplicity, which can appeal to a wider audience than the more complex designs. Ultimately, this design did not align with the end result the Sponsor was looking for and was not selected to move forward.

Concept D

Pros: Concept D was a very unique design that drew inspiration from the Sponsor’s windows and had a unique shape to it that is unlike anything currently on the market. The aesthetics of this concept really set it apart from the other concepts.

Cons: Due to its complex design, Concept D’s downfall came with the high costs and the low manufacturability and ease of use. Two criteria that were not the main focus of the Sponsor, but had a crucial effect on the concept.

Takeaways: Concept D was the runner up to Concept A because of its unique design. Concept D lacked in areas that could not be made up for because its design was so complex that it would have a high cost and a low manufacturability.

Table 7.2: Concept Selection Matrix for Strainer Design

Selection Criteria	Weight	Reference Concept		Concept A		Concept B		Concept C		Concept D	
		Ranking	Weighted Score	Ranking	Weighted Score	Ranking	Weighted Score	Ranking	Weighted Score	Ranking	Weighted Score
Cost	5%	3	0.15	3	0.15	3	0.15	3	0.15	3	0.15
Aesthetic	50%	3	1.5	5	2.5	4	2	2	1	5	2.5
Durability	10%	3	0.3	3	0.3	4	0.4	4	0.4	3	0.3
Ease of Manufacture	15%	3	0.45	4	0.6	4	0.6	5	0.75	3	0.45
Ease of Assembly	10%	3	0.3	4	0.4	3	0.3	4	0.4	3	0.3
Functionality	10%	3	0.3	5	0.5	4	0.4	4	0.4	4	0.4
Overall Score			3		4.45		3.85		3.1		4.1

7.6 Butt Plate Concept Generation

A snare drum needs a butt plate in order to secure the snares on the drum shell. Along with functionality, this drum part needs to be aesthetically pleasing to the eye. Customers need to want to look at their drum and be proud of every single piece on it. The goal of this design piece is to be something unique and unlike anything else on the market. The team wants the sponsor’s

drum to look original and classy because that is the style that he is going for. The sponsor's satisfaction is the number one priority.

Concept A

Concept A is a simple, yet appealing design. The design uses two pieces of sheet metal to potentially hold the snare wires on the drum. Because it is so limited in material, the cost to make this product would be relatively low. The piece has sharp edges and is a bit plain. There are similar butt plates to the one designed out on the market today. This design is highly functional, but it could use a bit more creativity.

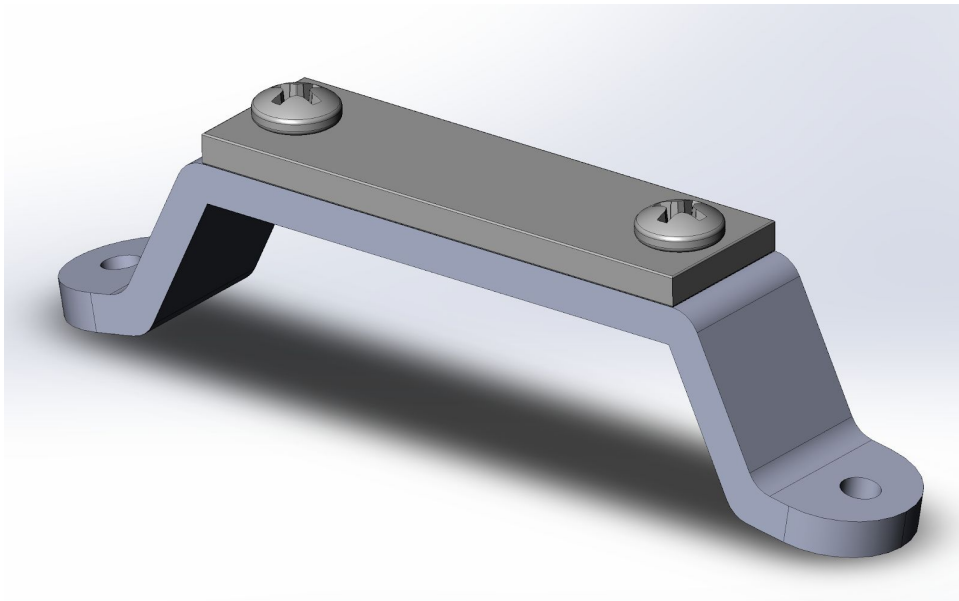

Figure 7.6.1: Concept A Butt Plate

Concept B

This concept is a little bit more intricate than the first concept. The design possesses a lot of fillets and curves, making the item more aesthetically pleasing. This is in fact a cast product due to the fact that the inside of this piece is solid, rather than hollow. The increase in material will however make this piece a little bit on the pricey side. This piece is definitely a nicer sight to look at on a drum and will be quite durable due to the piece being full of material.

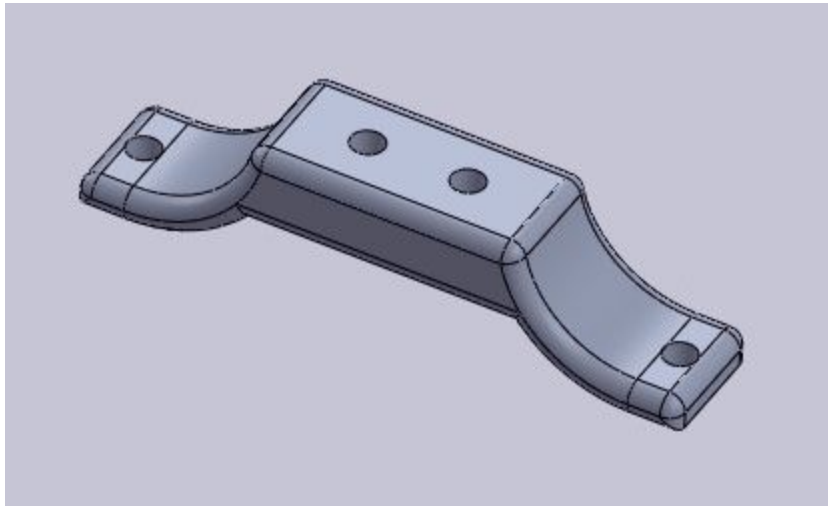

Figure 7.6.2: Concept B Butt Plate

Concept C

Concept C is very unique in terms of the other two designs, and also in terms of what butt plates exist already. This butt plate is very original and aesthetically pleasing. The design is based off of windows at the sponsor's cabin. This place holds near and dear to the sponsor's heart. The butt plate is a cast design and is quite durable because of that. The assembly may be a bit trickier on this piece because of the hard turned edges.

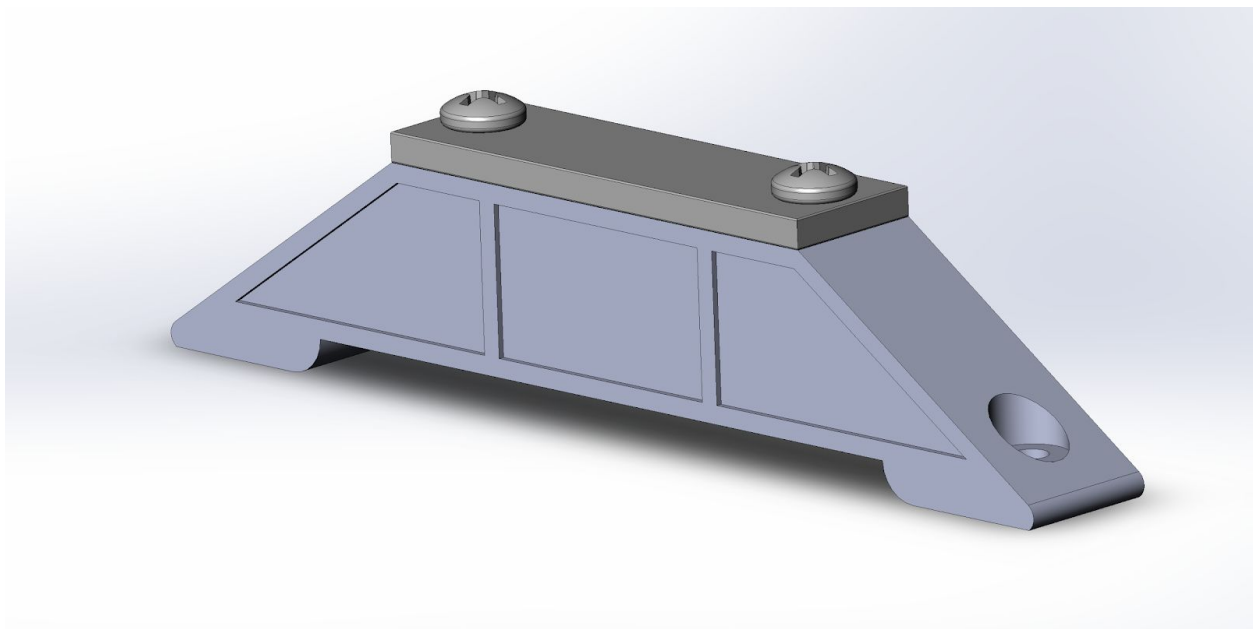

Figure 7.6.3: Concept C Butt Plate

7.7 Butt Plate Concept Selection

With multiple butt plate designs, the team will use a concept selection matrix to determine which concept is the best for the team's sponsor. The matrix emphasizes what aspects a design excels in and what aspect the design may need some improvement in. As stated earlier in the proposal, the most important variables were chosen off of the customer needs matrix. The variables consist of cost, aesthetic, durability, ease of manufacture, ease of assembly, and functionality. Each concept was scored against a reference concept. For the butt plate reference concept, the team used a Ludwig P32, which is an acceptable butt plate, but the team wanted to create a design that's even better than that one. The concept selection matrix is shown in Table 7.7 where the variables, weights and scores are shown. The concept selection matrix is used to find the best concept introduced.

Concept A

Pros: Because Concept A is made only out of two sheet metals, the piece will be extremely easy to manufacture and will not cost a lot to produce because there is so little material needed. This piece is also easy to assemble because it only involves putting one flat metal piece onto another.

Cons: This design is not extremely pleasing to the eye, being that it is relatively a basic design that has been done before. Along with it not being very unique, it is also not very durable because the metal pieces are thin.

Takeaways: Overall, this butt plate is great in terms of cost and manufacturing. The sponsor preferred us to cast the butt plate, but using sheet metal would make life a lot easier. In contrast, the butt plate is rather plain and does not possess the pizzazz that the sponsor is looking for.

Concept B

Pros: Concept B's design is more on the aesthetically pleasing side with nice, curved edges and soft features. Something simple is what the sponsor is looking for. The piece is also thick and very durable if the drum were ever to drop. This piece is made by casting and is relatively easy to assemble, by just adding a sheet plate on top.

Cons: This butt plate design will cost a little more because there are more materials needed. The functionality aspect may also be on the lesser side due to the fact that the piece has curved edges where the snares may not stay in place.

Takeaways: This design excels in the aesthetics category besides the curved edge on the part that holds the snares in place. The piece will be a little more on the pricey side, but with that comes higher durability and ease of manufacture.

Concept C

Pros: This concept is exactly what the sponsor was looking for in terms of aesthetics. The idea is different and original where it has not been done before. It is also based on something meaningful to him. The design is castable and relatively easy to manufacture. The solid piece makes the butt plate extremely durable.

Cons: Because this item is a bit larger and thicker, it may cost more to produce because more material is being used. It also may be a bit harder to assemble because the part is primarily curved.

Takeaways: This butt plate design exceeds any of the other concepts in regards to looks. It is durable and easy to manufacture, but it is a bit pricey and may be a bit harder to assemble.

Table 7.7: Concept Selection Matrix for Butt Plate Design

Selection Criteria	Weight	Reference Concept		Concept A		Concept B		Concept C	
		Ranking	Weighted Score	Ranking	Weighted Score	Ranking	Weighted Score	Ranking	Weighted Score
Cost	5%	3	0.15	5	0.25	4	0.2	3	0.15
Aesthetic	50%	3	1.5	3	1.5	4	2	5	2.5
Durability	10%	3	0.3	2	0.2	4	0.4	5	0.5
Ease of Manufacture	15%	3	0.45	5	0.75	4	0.6	3	0.45
Ease of Assembly	10%	3	0.3	5	0.5	3	0.3	3	0.3
Functionality	10%	3	0.3	4	0.4	3	0.3	4	0.4
Overall Score			3		3.6		3.8		4.3

8.0 Beta Prototype Details

8.1 Building upon Alpha Prototype

After our initial concepts and designs were discussed and clarified from our Alpha Prototype, the team was set on refining our lugs and continuing onward with our design process with the strainer. Our Alpha Prototype was well received by our sponsor. The feedback we received was critical in improving our design. The team came in with the goal to improve our drum lug and to create another prototype that better fit our sponsors vision. His vision aligned with our goal in terms of the overall shape.

Our sponsor thought the shape was too bulky, in terms of height, and the team was at the same general consensus. The height dimension, distance in radial direction, was not constrained properly. This was due to the team not having the dimension of the drum rim. The drum rim affects the positioning of the lugs and the desired distance outward from the shell. After clarifying our dimensions with our sponsor, we were able to quickly adjust the design to accommodate the updated parameters. By correcting our design, we were able to create a lug that will truly fit the desired shell, but also solved our issue regarding aesthetics. This change allowed for the team to update our design to a slimmer, more streamline, aesthetic for the lug. Overall, our aesthetic fix, for our Beta Prototype lug, led to our design maintaining its ease of manufacturability, while also solving dimensional and aesthetic concerns.

With our lugs adjusted and being finalized, the team began the process of strainer designs. Our initial designs focus on function and aesthetic. This was the biggest challenge as the aesthetics are a major part of our goal for the entire project. After speaking with our sponsor regarding strainer options, his feedback guided us towards the design options we drafted. From there, we used our concept selection process to determine the strainer design we would continue forward with. Overall, our strainer designs gave us insight on future problems and design challenges that we will be working through.

8.2 Critical Functions of Major Components

8.2.1 Drum Lug

The drum lug is a very critical part of the snare drum's function. The lugs on drums are typically cast components that mount to the shell of the drum so that the head can be tensioned. This function is critical for the overall function of the drum, as well as the tuning retention for higher quality drums. Any vibrations or misalignment can compromise the integrity of the sound. Knowing this, the lug needs to be mounted securely and rigidly so that the lug doesn't rotate or vibrate under tension. The lug also needs to be able to be manufactured easily as well as allow for the tension rod to float inside the chamber. This floating allows the tension rod to stay aligned to the holes in the rim and stay vertical. This is a critical aspect to keep the drum tuned for long periods of time.

8.2.2 Snare Strainer

A very critical component of a snare drum is the part commonly referred to as a strainer. Snare Drum gets its name from the snare attached to the bottom of the drum to provide the drum its unique sound. Snares are metal wires which are closely aligned in a specific set of patterns to provide a sound when the drummer hits the top portion of the drum also called a Drum Head. The lower part of the Snare drum is called a snare head as it is attached to the snares. The sound of each drum can be customised by changing the amount tension in the snares. The adjustment of snares allows the drummer to adjust the pitch, depth and tonal character of the sound to the required levels. Strainer is the tool which allows the drummer to set the tension or adjust it according to his liking. The adjustment is made in the strainer through a tension knob and tension lever that control the amount of contact between snares and the drum, for a customisation of sound according to the liking of the drummer.

8.2.3 Butt Plate

Butt plate along with Strainer helps the drummer to adjust the pitch, depth and tonal character of the sound, almost like gears for the tune. Butt plate is attached to the opposite side of the strainer and it is static in nature to keep a constant tension among the snares for a consistent sound performance. Along with the sound enhancement experience while drumming the butt plate also plays a very crucial role in aesthetics of the snare drum. The design of the butt plate has to be minimal in designing to follow the esthetic theme of the drum but at the same time has to provide unconditionally durable performance as it plays an extremely crucial role in the performance of the drum set.

8.3 Evaluation of Beta Prototype and Key Takeaways

After the process of concept selection and generation, prototyping of samples was our main objective. Prototyping that we followed, consisted of very closely dimensioned sample products, 3D printed to millimeter accuracy. After a lot of discussion about other approaches for prototyping, we used 3D printing as our primary manufacturing process technology for real size samples because of three primary reasons. Firstly 3D printed parts are extremely economical to manufacture and as our group has financial constraints, this was the most economical compared to other alternatives like casting. Secondly as one of our group members already had a 3D printer at home, it made the time from designing samples to real dimensional prototyping exponentially fast. Lastly it was the fastest medium of concept generation that we could apply as we could now follow the approach of rapid prototyping, which basically allowed us to print a lot of prototypes at once, along with saving a lot of time as well as helping evaluate and compare the printed samples.

The primary challenge of our design, from the customer needs and importance matrix chart was the aesthetic appeal of our products to a very specific niche audience. It is very difficult to quantify a subjective opinion like design in numbers for evaluation. Therefore along

with many tests and surveys, our primary source of guidance was the experience of our project sponsor Sam in designing drums and the likes of people of specific drummers industry. Therefore, we worked very closely with our project sponsor in getting his opinions on our designs and what type of a design approach he desires for the aesthetics of the designed components. Throughout the process of evaluating prototypes, our team followed the concept of “Test early, Test often.” We generated closely monitored samples and tried to simplify the design in a curvy aesthetic manner to give an appeal of simplicity in our products, but at the same time aesthetically pleasing to give HHG drums a unique and differentiating USP in front of the competitors. Overall, our beta prototype fulfilled the team's aesthetic aspirations as well as prototyping goals, and allowed us to test print our strainer and share our initial designs with our sponsor for feedback.



Figure 8.3: 3D Printed Strainer

8.4 Plans for Redesign and Gamma Prototype

After reviewing the team's beta prototype, the team has finally come up with a lug design that they are happy with. The team altered the alpha prototype design ever so slightly to make the

lug just a little thinner and shorter so it wasn't so bulky when placed on the drum. The team kept with the barrel nut design and the sponsor loves how it turned out!

Having the lug completely finished has allowed the team to move onto concept generation and selection for the strainer. With feedback from the sponsor, he inevitably loved all of the designs we presented to him and said for us to take the path in which we desire the most. With that being said, the team collectively decided that the hourglass shaped strainer was the best route to take because that size and shape is very uncommon in the market today. The team knows that they could easily produce any kind of strainer they like, and the sponsor would love it, but the team's goal is to bring something unique to the table for the sponsor to be extremely proud of. The team is very proud of the winning strainer because it is so different and unique.

For the butt plate, the team is extremely thrilled that they could add a personal story to the design. It makes it very unique to competitor's designs. The final butt plate needs to be functional, along with being aesthetically pleasing. The team may adventure into even more ideas for the butt plate, permitting time. The team would like to present follow up ideas with the sponsor to see which designs he leans towards. Essentially, the team would like to have both the strainer and the butt plate somewhat match the lug, to keep a cohesive theme among the drum parts.

Our team is currently researching options for testing the manufacturability of the parts we create. We plan to use a casting simulation software such as Altair to make sure the part can be cast without solidifying first. This software will also allow us to add the necessary geometries for casting. The goal is to make all of the parts manufactured by casting, to decrease production hassles.

Our gamma prototype will include a redesigned model of the butt plate, and will also display 3D printed models of each part. We will also include detailed analysis of the manufacturability of each part.

9.0 Final Prototype Details

9.1 Building upon Beta Prototype

9.1.1.a Strainer Redesign Concept Generation

With the final strainer concept selected at the end of the beta prototype phase, the team decided to design one more strainer to see if that one better fit the customer needs and sponsors desires. The team allowed the sponsor to look at both designs and see which one he liked more. Both designs were well thought out and creative, so the winner was left up to the concept selection matrix for the two ideas.

Concept A

Introducing the first strainer design, Concept A, with a body shape that mimics the curvature of the snare drum itself. This sleek, yet simple, design incorporates many different aesthetic types. The geometric rectangular base emphasizes and compliments the curves of the body of a strainer. The basic screw seen at the top of the strainer and the lever shows on the side add to the simplistic design. More importantly, the basicness of the design makes it easy to manufacture, which has been a priority from the start of our design process.

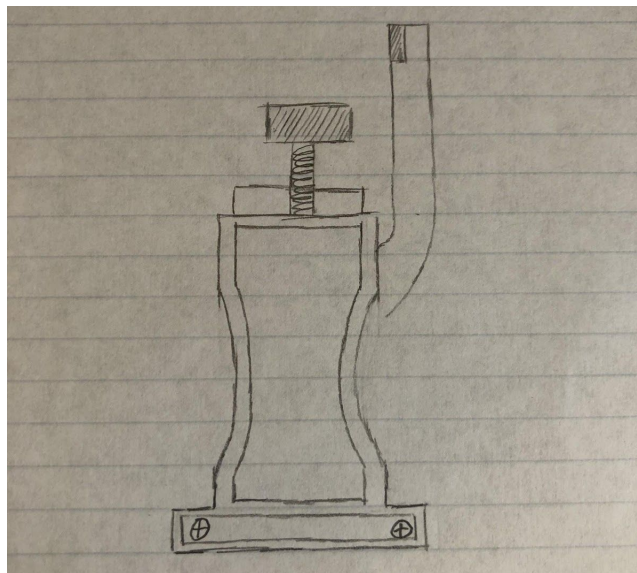

Figure 9.1.1.a Concept A for Strainer Design

Concept E

This concept has a similar look to the base of Concept A, except with more curved edges, giving the component a more natural feel to it. The hardware also has a large circle piece attached to the back of the base to help guide and move the lever up and down. This piece creates a maximum distance that the lever can travel. There are no designs out on the market that even closely resemble a strainer like this one. That is extremely beneficial in making HHG Drum components look unique and intriguing.

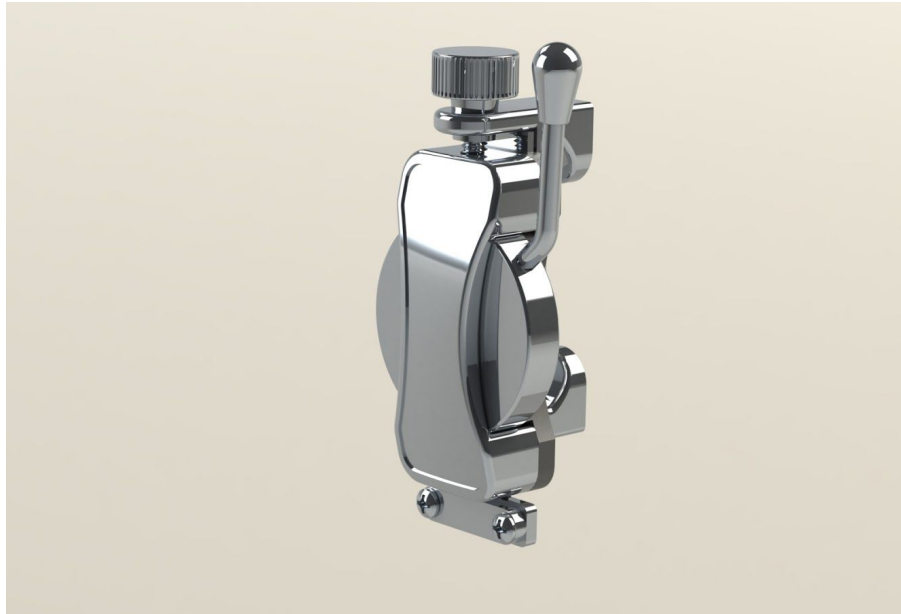

Figure 9.1.1.a Concept E for Strainer Design

9.1.1.b Strainer Redesign Concept Selection

Pros and Cons

Concept A

Pros: Concept A is a simple and classy design that is relatively easy to assemble and manufacture. Its high functionality levels also gave it an advantage over the other designs. The low cost to develop and manufacture was another positive attribute of the design. Overall, this design meets the unique aesthetic that the Sponsor was going for.

Cons: Concept A scored very well relative to the other strainer designs. There are no stand alone concerns regarding this design. The design is unique which can raise concerns that this design may not be for all customers.

Takeaways: Ultimately, Concept A scored the highest among all of the designs and was chosen to move forward with. The geometric shape and ease of manufacturing and assembly were key contributors as well as its aesthetic design. The sponsor reacted the most positively to this design.

Concept E

Pros: Concept E is extremely unique and has never been done before. When someone sees this strainer, they will know that HHG Drums created it. The function of the lever is extremely clever and unlike anything seen before. The product is also easy to case with the rounded edges.

Cons: There are a lot of pieces to this strainer, so the cost may be a little more expensive. Other than that, there are no more cons to this design.

Takeaways: This design is very creative and outside of the box. Customers will love the uniqueness of it. The sponsor was thrilled with this product outcome.

Table 9.1.1.b: Strainer Concept Selection Matrix

Selection Criteria	Weight	Reference Concept		Concept A		Concept E	
		Ranking	Weight	Ranking	Weight	Ranking	Weight
Cost	5%	3	0.15	3	0.15	2	0.1
Aesthetic	50%	3	1.5	5	2.5	5	2.5
Durability	10%	3	0.3	3	0.3	5	0.5
Ease of Manufacture	15%	3	0.45	4	0.6	4	0.6
Ease of Assembly	10%	3	0.3	4	0.4	4	0.4
Functionality	10%	3	0.3	5	0.5	5	0.5
Overall Score			3		4.45		4.6

9.1.2.a Butt Plate Redesign Concept Generation

Concept C

Concept C is very unique in terms of the other two designs, and also in terms of what butt plates exist already. This butt plate is very original and aesthetically pleasing. The design is based off of windows at the sponsor's cabin. This place holds near and dear to the sponsor's heart. The butt plate is a cast design and is quite durable because of that. The assembly may be a bit trickier on this piece because of the hard turned edges.

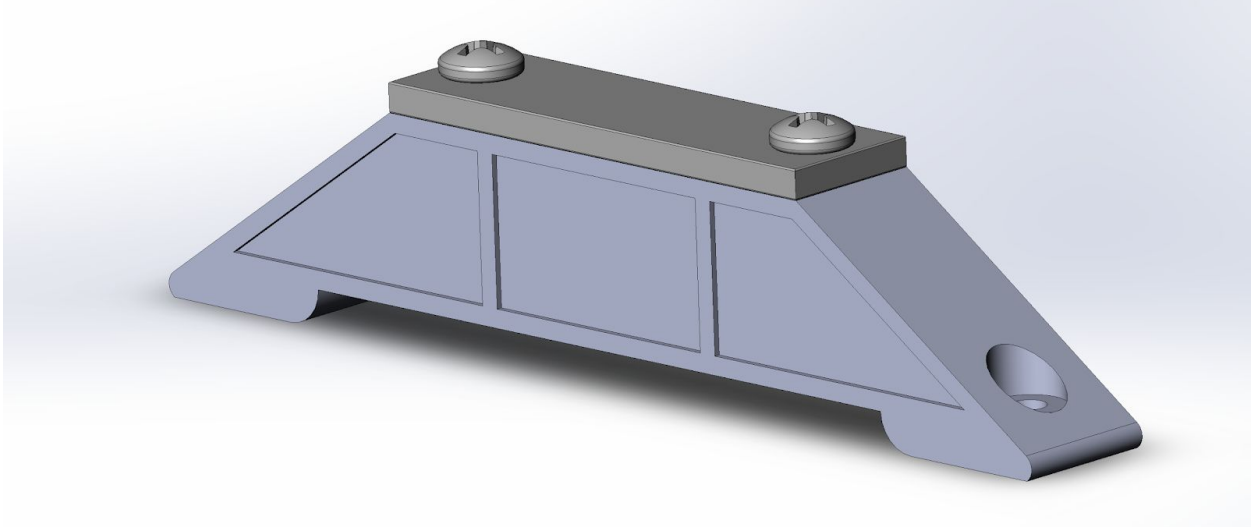

Figure 9.1.2.a: Concept C Butt Plate

Concept D

This concept consists of a rounded hardware piece which goes along with the aesthetics of the drum. Due to its rounded edges, the piece blends in with the drum, while being able to function properly. The design consists of a clasp that moves up and down, along with screws to keep the snare wires in place. This design also has an extruded ridge going down the center of the piece, resembling the lug created, keeping all of the hardware coherent among each other.



Figure 9.1.2.a: Concept D Butt Plate

9.1.2.b Butt Plate Redesign Concept Selection

Pros and Cons:

Concept C

Pros: This concept is exactly what the sponsor was looking for in terms of aesthetics. The idea is different and original where it has not been done before. It is also based on something meaningful to him. The design is castable and relatively easy to manufacture. The solid piece makes the butt plate extremely durable.

Cons: Because this item is a bit larger and thicker, it may cost more to produce because more material is being used. It also may be a bit harder to assemble because the part is primarily curved.

Takeaways: This butt plate design exceeds any of the other concepts in regards to looks. It is durable and easy to manufacture, but it is a bit pricey and may be a bit harder to assemble.

Concept D

Pros: This concept is most importantly pleasing to the eye. The sponsor was very thrilled with the design the team came up with. This piece is also easy to cast due to the rounded edges. It is extremely durable because the inside of the piece is solid. It is also very easy to assemble because it is a simple clasp that is held together by two screws.

Cons: The only downside to this piece is that it is going to be an average price due to how bulky it is. But the customer would get that for any butt plate being purchased.

Takeaways: Overall, this butt plate is aesthetically pleasing and is very durable and functional. The piece may cost a bit, but it is definitely worth it for the looks.

Table 9.1.2.b: Butt Plate Concept Selection Matrix

Selection Criteria	Weight	Reference Concept		Concept C		Concept D	
		Ranking	Weight	Ranking	Weight	Ranking	Weight
Cost	5%	3	0.15	3	0.15	3	0.15
Aesthetic	50%	3	1.5	5	2.5	5	2.5
Durability	10%	3	0.3	5	0.5	5	0.5
Ease of Manufacture	15%	3	0.45	3	0.45	5	0.75
Ease of Assembly	10%	3	0.3	3	0.3	5	0.5
Functionality	10%	3	0.3	4	0.4	5	0.5
Overall Score			3		4.3		4.9

9.2 Subsystems and Critical Functions

9.2.1 Drum Lug

The drum lug is a very critical part of the snare drum's function. The lugs on drums are typically cast components that mount to the shell of the drum so that the head can be tensioned. This function is critical for the overall function of the drum, as well as the tuning retention for higher quality drums. Any vibrations or misalignment can compromise the integrity of the sound. Knowing this, the lug needs to be mounted securely and rigidly so that the lug doesn't rotate or vibrate under tension. The lug also needs to be able to be manufactured easily as well as allow for the tension rod to float inside the chamber. This floating allows the tension rod to stay aligned to the holes in the rim and stay vertical. This is a critical aspect to keep the drum tuned for long periods of time.

9.2.2 Snare Strainer

A very critical component of a snare drum is the part commonly referred to as a strainer. Snare Drum gets its name from the snare attached to the bottom of the drum to provide the drum its unique sound. Snares are metal wires which are closely aligned in a specific set of patterns to provide a sound when the drummer hits the top portion of the drum also called a Drum Head. The lower part of the Snare drum is called a snare head as it is attached to the snares. The sound of each drum can be customised by changing the amount tension in the snares. The adjustment of snares allows the drummer to adjust the pitch, depth and tonal character of the sound to the required levels. Strainer is the tool which allows the drummer to set the tension or adjust it according to his liking. The adjustment is made in the strainer through a tension knob and tension lever that control the amount of contact between snares and the drum, for a customisation of sound according to the liking of the drummer.

9.2.3 Butt Plate

Butt plate along with Strainer helps the drummer to adjust the pitch, depth and tonal character of the sound, almost like gears for the tune. Butt plate is attached to the opposite side of the strainer and it is static in nature to keep a constant tension among the snares for a consistent sound performance. Along with the sound enhancement experience while drumming the butt plate also plays a very crucial role in aesthetics of the snare drum. The design of the butt plate has to be minimal in designing to follow the esthetic theme of the drum but at the same time has to provide unconditionally durable performance as it plays an extremely crucial role in the performance of the drum set.

9.3 Prototype Evaluation

Our final prototype for each part fulfilled the goals of the project. The final Strainer design was especially unique due to the change in the composition of the design. Utilization of a

rotating disc to offer similar motion, allowed for the design to reduce the number of pieces in the assembly. This reduces the cost and results in less components needing to be manufactured. This design is also incredibly unique and its aesthetics are unmatched across competitors.



Figure 9.3. Final Lugs and Butt Plate rendered on drum

9.3.1 Testing

Prototypes produced allowed for the team to analyze potential manufacturing concerns and functionality concerns. Our team attempted low quality casting production for the lug hardware. The process was very simple, and different than the magnitude of the process of die casting commercially, but allowed for the group to see potential problems that might need to be faced. Making sure that our lug design would be manufacturable was one of our main priorities. Adjusting the angles and design allowed for us to develop the design to its current final state. Through this testing, we could ensure that the lug could be casted and are confident now that the sponsor will be able to manufacture these parts. Beyond just casting, the group also 3D-printed many components to see how they meshed together with other parts. Rapid prototyping allowed us to show our sponsor designs and ideas physically, while also ensuring quality and sizing were accurate.



Figure 9.3.1.a. 3D Printed Strainer



Figure 9.3.1.b. Casted Lugs

9.4 Lessons Learned

Our final prototypes capture the unique aesthetic HHG Drums was going for, but it was not achieved in one fell swoop. Our team quickly learned in the concept selection process that multiple rounds of concept generation are needed to achieve our desired final design. This along with active participation from our sponsor proved helpful as we were able to pick up on his verbal and nonverbal cues regarding the designs that we showed him. Showing our sponsor our final designs and seeing him in awe with excitement just further emphasized the need to keep him included in our design process. Another lesson that the team learned throughout the prototyping phase that was a big contributor to our success is that we pulled out the team members that had strong CAD modeling skills and they were able to all work on the CAD files together which not only gave each of them a break but it allowed for more perspective to be brought in compared to if only one person was in charge of the CAD models. The final prototypes were the most detailed of all of our designs and utilizing our strong team environment ensured a successful final product.

10.0 Next Steps

10.1 Next Steps for Subsequent Capstone Team

Further development for the parts designed by the group will not be needed by a future team. However, HHG could partner with Penn State and the Learning Factory again to fully produce and develop the design further. The strainer had too many components to attempt to cast ourselves, but could be done with more time and would allow for tests to be done on a sample shell. It could be installed and used functionally to find potential areas of improvement. For example, the ergonomics of the handle tends to be important for the end user and how they feel about the motion of the strainer. This can be adjusted and remade very easily with the addition of a threaded handle. Unfortunately, the team did not have the required equipment or support to handle this during the current situation and time constraints of the project. Overall, our design fulfills HHG drums goal and vision perfectly, but there is always room for improvement and further development.

10.2 Next Steps for HHG Drums

Now that all of the drum components have been created, the execution of these hardware pieces is the only thing that is left. The team has sent over all CAD files to the sponsor so he can have access to them when he is ready to mass produce the components. The sponsor will have to invest a lot of money in the manufacturing and purchasing of these pieces, so he hopes to save up and get the parts produced within the next five years. As for the places he could get them manufactured, the team has created a list of places that will produce small smarts like these components in which he can sort through and get quotas for prices. The team is also going to send the sponsor all of the 3D printed and casted pieces so he can reference them when needed (or brag about how good of a job we did). The team hopes to keep in touch over the years and keep a lookout on the sponsor's Instagram page for when he finally produces the parts. The sponsor also has all of the team member's contact information if he ever needs to get in touch with us about the components created.

References

“S.L.P. Classic Maple 5.5‘x14’: S.L.P.: SNARE DRUMS: PRODUCTS.” *TAMA Drums*,
www.tama.com/usa/products/snare_drums/slp_classic_maple_snare_drum.html.

“BPMH460LNW.” *Mapex Drums*,
mapexdrums.com/us/products/drums/snare/bp-design-lab/bpmh460lnw/.

“BPCW4600CNW.” *Mapex Drums*,
mapexdrums.com/us/products/drums/snare/bp-design-lab/bpcw4600cnw/.

Appendix

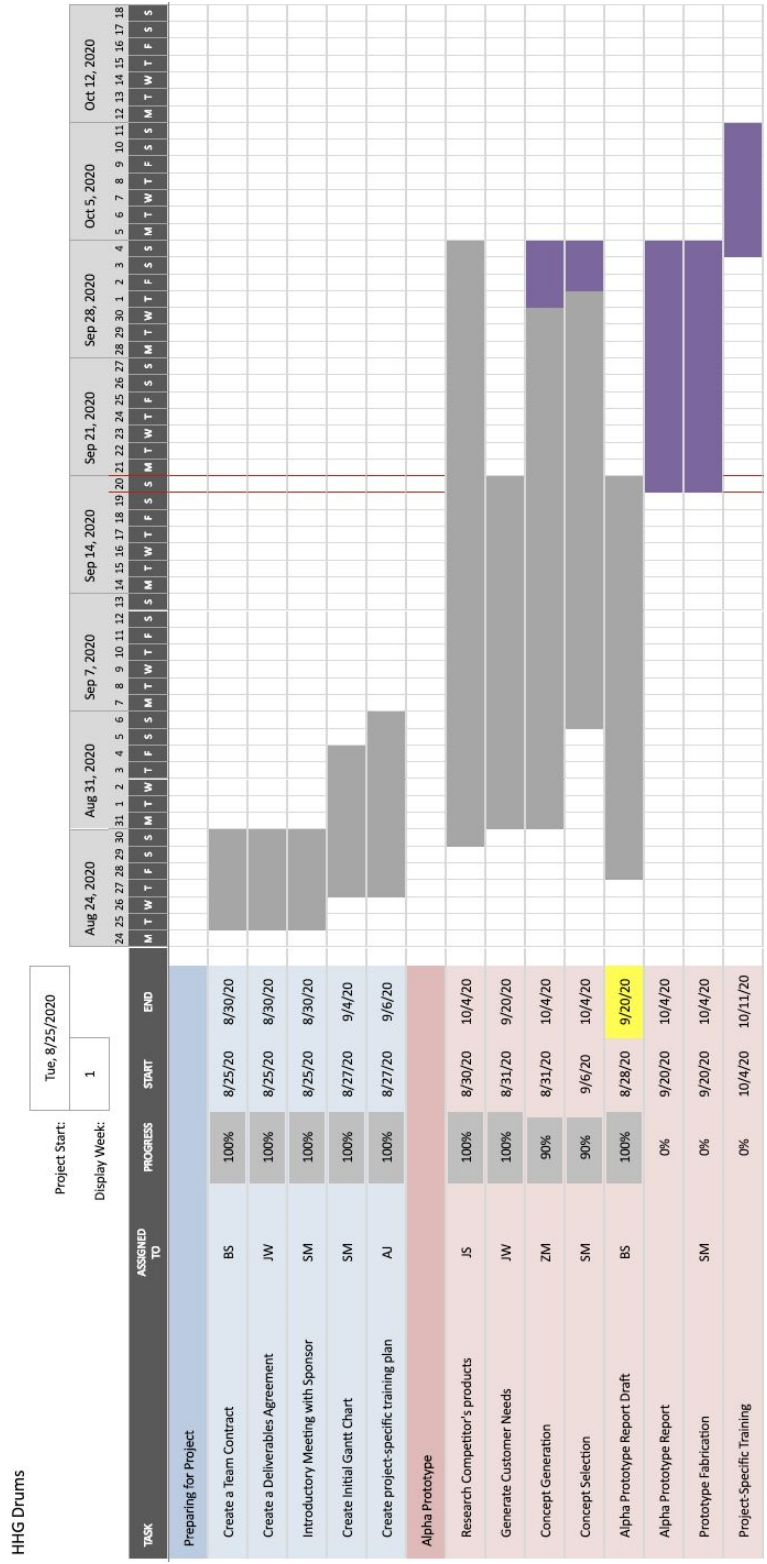

Figure A. Gantt Chart